

The Tapworks Whole Home Filter

Specifications

Flow rate at 1 bar pressure drop	41.6 litres/min.*
Maximum daytime pressure	4.76 bar
Minimum daytime pressure	1.7 bar
Supply water temperature limits (minimum/maximum)	5 – 49 °C
Drain flow rate	12.9 litres/min
Estimated total capacity	2,044 cubic metres*

* From independent laboratory test data

Dimensions

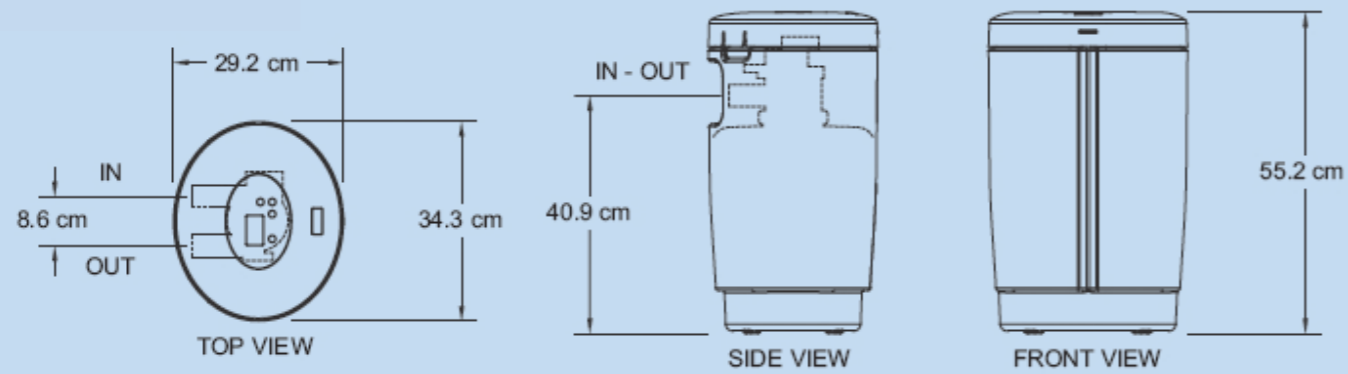

Filtered water for every tap in the home
Pure Genius.



TAPWORKS®

Tapworks, Mill Road, Stokenchurch, Bucks HP14 3TP
 Direct Service Line: 01494 480 621 Fax: 01494 484 396
www.tapworks.co.uk

As part of our policy of ongoing research and development, we reserve the right to alter design and specification without prior notice.

*Subject to the terms of our 2-year warranty.

The Tapworks Whole Home Filter

Pure genius from the manufacturers of the world's number 1 water softener – removes chlorine and sediment along with installation and maintenance hassles.

TAPWORKS®

The latest innovative product from Tapworks provides freshly filtered water to every tap in the home. Designed for the many households in the UK who don't like the taste or smell of their mains supplied water, the Whole Home Filter removes chlorine and sediment for purer water that customers will love. Used on its own or as the perfect partner to a Tapworks water softener, this easy to install product eliminates maintenance worries with a filter that lasts up to 8 years.

Great tasting, pure smelling water throughout the home

The Whole Home Filter removes the nasty smells, tastes and sediment that an increasing number of customers hate. It's the perfect product for installers to recommend to all sorts of families including those with young children, a preference for bottled water or big laundry requirements. With the Whole Home Filter installed, customers will benefit from:

- **Great tasting water on tap for a fraction of the cost of bottled water**
- **The elimination from water supplies of chlorine smells and tastes**
- **Fewer trips to the supermarket and wasteful plastic drinking water bottles**
- **Delicious, pure-tasting tea and coffee**
- **Better tasting cooking as fruits, vegetables, pasta, rice and other foods are prepared using freshly filtered water**
- **Even better bath times with filtered water for everything from cleaning teeth to washing hair**



All this gives customers many reasons to appreciate the recommendation by their installer.

The number one choice of installers

As the world's largest supplier of domestic water treatment products, no one understands the needs of households better than Tapworks. Many customers want more than a single water filter tap in their kitchen, preferring instead to have chlorine and sediment free water throughout their home. The Whole Home Filter does the job beautifully and works alongside our water softeners where households also need a solution to hard water problems. You can recommend Tapworks with confidence knowing that over 2 million customers benefit from our technology worldwide.

Easy to install

The Whole Home Filter is fitted at the water mains point of entry in the property. Installation is simplicity itself, with mains water diverted through the product via the in-built connector. Once connected you simply power-up via a standard 13-amp socket, run the start-up cycle, set the clock and set the programme times. It's as simple as that and the household is ready for a continuous flow of filtered water.



Cut carbon emissions and costs too

The Whole Home Filter doesn't usually need servicing for 8 years, so the cost of filtering a litre of water is tiny. Customers will make significant savings on bottled water, fewer trips to the supermarket and eliminate wasteful plastic bottles – the combination of which is good news for the environment and household expenses.

No replacement filters, cartridges or mess

The Whole Home Filter cleanses water via our exclusive Filtersense™ technology. Based on typical household water consumption (250m³/year), the filter will provide high quality water for 8 years, with no maintenance, replacement filters, replacement cartridges or the like. And, in-built AutoRinse™ technology makes things easy by automating filter cleaning cycles.

All of this delivers convenience to customers while helping ensure that installers don't have to keep calling back.

Big company warranty

As with all Tapworks products, the Whole Home Filter is backed by our comprehensive warranty and team of experienced engineers. In the unlikely event of a problem with a Tapworks product† you can rest assured that we'll be there to put it right, exactly the service you'd expect from the World's largest domestic water treatment company.

Compact convenience without loss of pressure

The Whole Home Filter has the capacity to filter water for an entire household or even something bigger like a guest house, restaurant or bar. However this large capacity isn't at the expense of size as the product is compact enough to fit in a cupboard or small enclosure. Better still, water pressure is barely affected so householders will enjoy free flowing filtered water to every tap in their home.

Protection against sediment

Customers trust the advice and recommendations of installers, so will be especially pleased that, as well as pure tasting and clean smelling water supplies, they'll benefit in other ways too when a Whole Home Filter is installed in their home. Sediment that would otherwise be deposited in the water supply following routine maintenance by the water companies is filtered out at the point of entry, providing added protection throughout the home.

